

PRODUCT SPECIFICATIONS

SWIVEL AND EXPANSION RANGE

EXPANDER JOINTS - 90MM



It is recommended that an expander joint be installed at every change of direction on all H and E class sites, unless specified otherwise.

The correct installation of expander joints will allow for flexibility within a plumbing and drainage system.

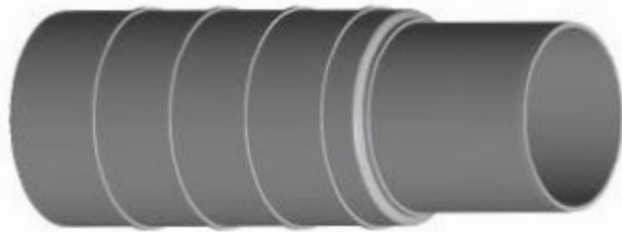
- Ideal for pipe repair work
- Water tight seal
- Complete with internal stop.
- Use in conjunction with Plastec Swivel or Flexitec Joints for reactive soil sites



NOTE: For H and E class sites it is recommended that expander joints be used in conjunction with swivel and combination joints (available for separate purchase).

ID	 DIAMETER	INLET	OUTLET	MAX. EXPANSION	 BAG QTY
15131	90	Pipe Size	Socket	100	11

Related Products:

- 100mm, 150mm and 225mm also available.
- Swivel and Combination joints and Flexitec fittings available for separate purchase.

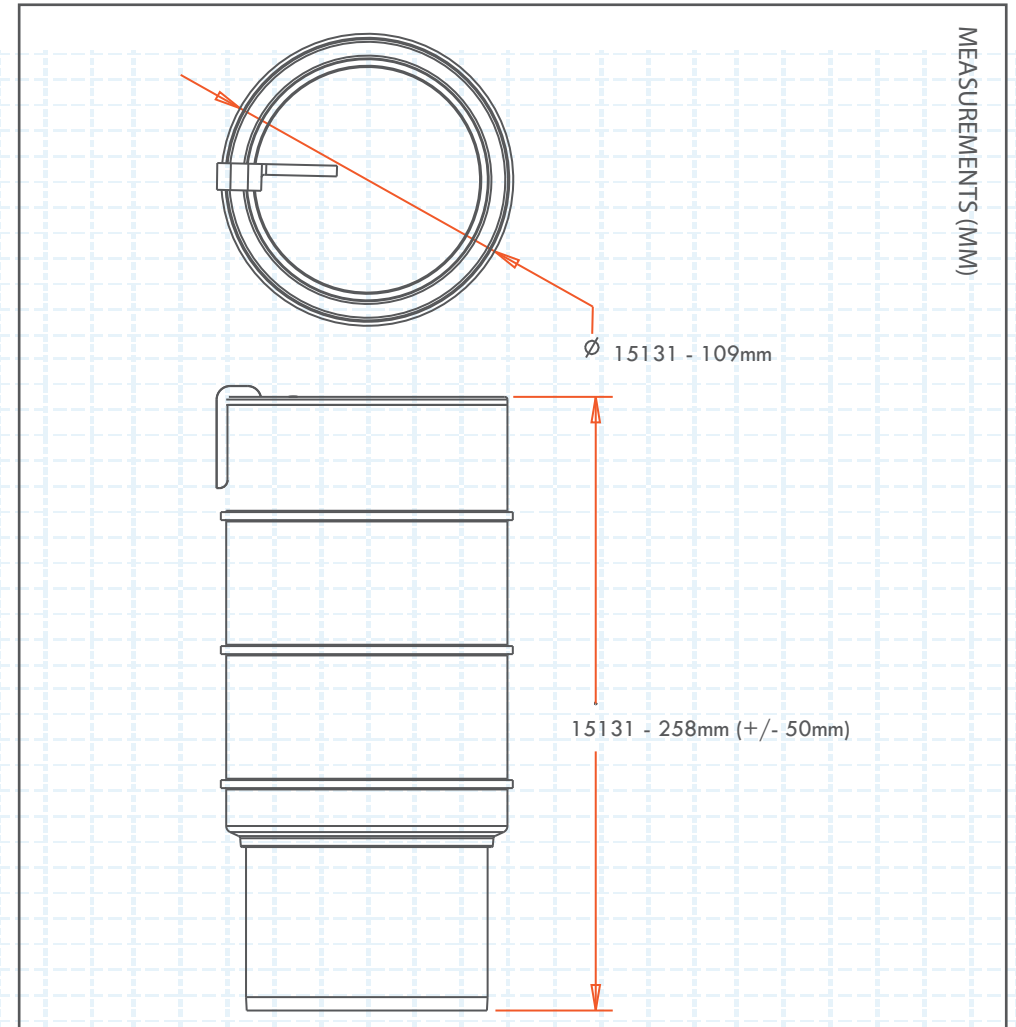

 DIAMETER
  FASTENING
  BAG QTY
  CARTON QTY
  FINISH/COLOUR
  MEASUREMENT (MM)

Details correct as at 11/08/2020, but are subject to change.

07 5413 4444 - WWW.PLASTEC.COM.AU